

A Framework for Various Approaches under the UNFCCC Necessity or luxury?

Andrei Marcu

No. 70 / November 2012



This report was prepared as a submission to the Ad Hoc Working Group on Long-term Cooperative Action under the Convention (AWG-LCA). It draws on discussions that took place among the members of the CEPS Carbon Market Forum (CMF).

The CMF provides a neutral space where policy-makers and regulators are able to meet carbon market participants and other stakeholders to discuss carbon market regulation and general policy issues. The contents of this report reflect the general tone and direction of discussions on specific topics within the CMF, but its findings do not necessarily represent a full common position agreed by all the participants in the CMF, nor do they necessarily represent the views of the institutions to which the participants belong.

Andrei Marcu is Senior Advisor and Head of the Carbon Market Forum at CEPS. The views expressed are attributable only to the author in a personal capacity and not to any institution with which he is associated.

ISBN 978-94-6138-242-9

Available for free downloading from the CEPS website (www.ceps.eu)

©CEPS 2012

All rights reserved. No part of this publication may be reproduced, stored in a retrieval system or transmitted in any form or by any means – electronic, mechanical, photocopying, recording or otherwise – without the prior permission of CEPS.

Executive Summary

The Framework for Various Approaches (FVA) under the UNFCCC will only cover mitigation actions, which produce units that are used for compliance with international obligations by a jurisdiction other than the one where they were created, or issued. These Approaches can be market- or non-market-based.

The FVA will be needed not only to create a liquid global carbon market, but also to allow some of the emerging national carbon markets to function properly. Many national carbon markets will find it challenging to be liquid on their own, and a market without liquidity will be dysfunctional, and give wrong price signals. The FVA is therefore not a luxury, but a necessity.

On the assumption that there is an international agreement under the UNFCCC to deal with what is a global issue, the UNFCCC will have to provide the institutional framework for the FVA. Since this will be a much more complex undertaking than what the Clean Development Mechanism ever aspired to be, it presents a challenge for the multilateral system. Significant changes will therefore need to be made to the current governance of the offset mechanisms in order to succeed.

The FVA includes many provisions (i.e. complexity) that are made necessary by the (assumed) disappearance of elements of the Kyoto Protocol (e.g. AAUs). This should provide food for thought to policy-makers.

Finally, we do not have the luxury of time. National systems are evolving rapidly, and they are starting to link. A failure to react in time will make future actions to 'retrofit' more expensive, when the need for harmonisation becomes evident.

So what is needed from the Doha COP in order to move forward? At the very least, we need 'political' direction on some fundamental elements that constitute the FVA: objectives, scope, and components, including some direction on the functions of each component.

A negotiated text that leaves too many of these fundamental building blocks unaddressed, or open to interpretation, will only lead to the creation of a FVA, which, like the Clean Development Mechanism (CDM), will require years of work and retrofit before it can reach its potential.

A Framework for Various Approaches under the UNFCCC: Necessity or luxury?

Andrei Marcu

CEPS Special Report No. 70 / November 2012

1. Introduction

Following the Copenhagen, Cancun and Durban Conference of the Parties (COP) meetings, it is becoming clear that we are moving towards a new climate change regime that in many ways will be very different from the Kyoto Protocol (KP) world in which we have been operating in recent years. This new climate change regime will determine how a global carbon market may emerge and operate.

The new world will likely be more fragmented, but, at the same time, may provide the advantage of being more adaptable to national circumstances. It could also prove more able to catalyse new ideas, at the regional, national or sub-national level.

Depending on the assumptions we make, if we want to ensure a well-functioning and liquid market, this may, ironically, require more complexity.

The current Kyoto Protocol provides for caps, and timetables and mechanisms to help achieve those caps. It divided the world along two axes; income and emissions, and created an imaginary line between the two (see Figure 1). Countries that were placed above that line, high income and high emissions, had to take caps, were allocated Assigned Amount Units (AAUs) and could trade AAUs among themselves under Article 17 of the KP.

Figure 1. Market Mechanism under the Kyoto Protocol

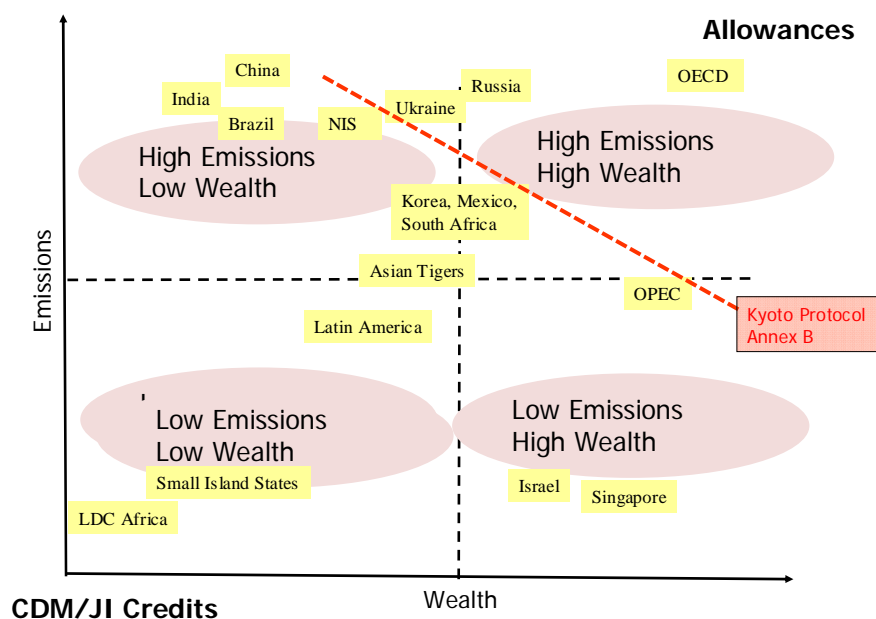

Source: D. Forrister.

Countries below the line could use the crediting mechanisms, the Clean Development Mechanism, to produce Certified Emissions Reductions (CERs), which could be used by countries with caps to meet their obligations in a more cost-efficient way. The resources that they received (technology, finance) were to be used for sustainable development.

The world has changed in many ways since the KP was drawn up. In one dimension, the line has moved from where it was before, as the economic circumstances of countries have changed. In addition, a two-dimensional world is not an accurate reflection of reality anymore; it is now much more complex than that.

The Cancun and Doha agreements point to a world where many initiatives are emerging, as all countries are doing their bit under UNFCCC principles. Figure 2 shows some of the market-driven initiatives that have appeared in the last few years, with many more expected in the future.

Figure 2. The trading world in January 2012

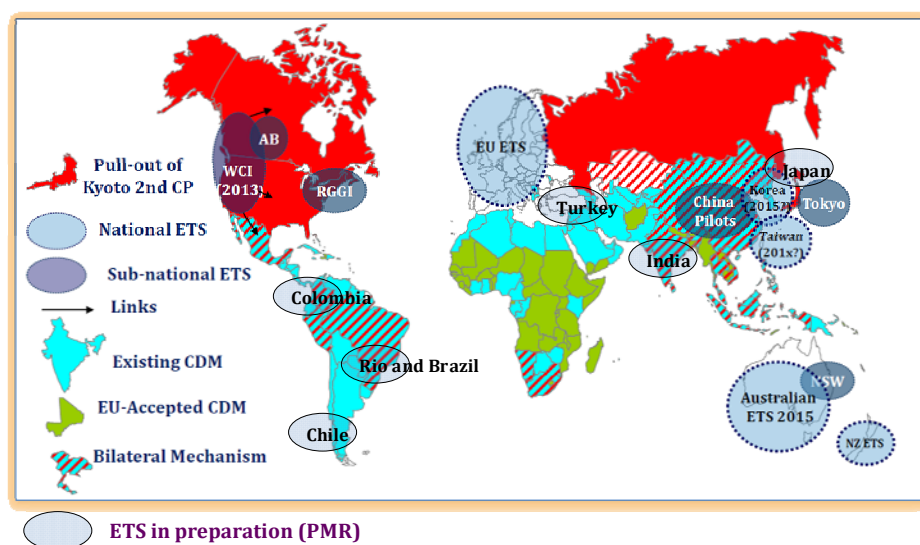

Source: IETA.

One of the key issues discussed in Durban at COP 17 was the definition of new approaches to help match the new level of ambition. The New Market Mechanism (NMM) and Various Approaches have become the new buzzwords.

As many of these new initiatives (some market-driven, some not) will emerge from the national level, integrating all this diversity into an international framework has also become an important issue – hence a Framework for Various Approaches (FVA).

The Durban COP provided a mandate for the one of its bodies, the Ad Hoc Working on Long Term Cooperative Action (AWG LCA), as outlined below:

- “To conduct a work programme to consider a framework for such approaches (including opportunities for using markets, to enhance the cost-effectiveness of, and to promote, mitigation actions, bearing in mind different circumstances of developed and developing countries), with a view to recommending a decision to the Conference of the Parties at its eighteenth meeting?”
- “Defines a new market-based mechanism, operating under the guidance and authority of the Conference of the Parties, to enhance the cost-effectiveness of, and to promote, mitigation actions, bearing in mind different circumstances of developed and developing countries, which is guided by decision 1/CP.16, paragraph 80, and which, subject to conditions to be elaborated, may assist developed countries to meet part of their mitigation targets or commitments under the Convention.”

This paper will focus on the FVA and examine the assumptions, objectives, scope, components and functions of a Framework for Various Approaches (FVA) that will allow for the creation of a well-functioning global carbon market to emerge.

During negotiations, Parties have expressed their intended objectives as:

- a) Minimising unnecessary international regulatory intervention in domestic mitigation actions;
- b) Having the desire to link different domestic actions;
- c) Maintaining a strong interest in ensuring environmental integrity.

This paper tries to examine all the possible scenarios in the world we are describing, and the inevitable complexities that follow.

As negotiations progress, some of the assumptions outlined below may prove false and lead to simplifications and the elimination of some of the provisions in this model.

From another angle, this paper also provides material to reflect on the implications for market functioning, environmental integrity, and accounting that would result from the elimination of some provisions and components inherent in the Kyoto Protocol structure.

2. Assumptions

In many ways the Durban decision to consider a FVA, and develop modalities and procedures for the NMM, is leading us to prepare for a climate change regime/framework that is yet to be defined.

This increases the complexity of the discussion, as many unknowns have to be addressed and provided for. However, as the science tells us through the Intergovernmental Panel on Climate Change (IPCCC) report, doing things sequentially (i.e. waiting to 2015 to start discussions on the FVA), is simply not an option.

What is important, however, is to develop an FVA that is resilient enough to ensure continuity; one that works during KP2, and that does not have to be changed post-2020.

In order to discuss the FVA, the new climate change regime needs to be described. This analysis is based on a number of assumptions, namely:

1. There will be an international climate change regime under the authority of the COP.
2. It will have end-of-period compliance obligations where units used for compliance will have to be accounted for with the Regulator, the COP.
3. There will be an end-of-compliance period inventory.
4. There will be no AAUs.
5. Some countries will have economy wide caps or targets. They could be developed countries, or developing countries, that choose to present their efforts in this way. At the same time, such commitments/caps/targets could be made at a sub-national, sectoral, or multi-sectoral level, not only nationally. The UN climate change framework will give recognition to these commitments, under certain conditions, which will need to be elaborated. However, this discussion is beyond the scope of this discussion.
6. Countries that transfer outside the country a unit, will add to their inventory that amount of CO₂ (e.g. +1). Countries that receive the unit transferred will see their inventory go down by the same amount (e.g. -1).
7. Various Approaches at the regional, national or sub-national level will create reductions. Some of them will be market driven, while others will be based on non-market actions. **The**

FVA that is being discussed in this paper can be applied to all Various Approaches, but will refer, for reasons of simplification, to market-based approaches/mechanisms only.

8. A number of carbon market mechanisms will emerge around the world. Some of them will be designed and developed by the UNFCCC, and implemented voluntarily by Parties. They will issue units whose standards are under the authority of the UNFCCC. CERs, and possibly NMM units, are in this category. However, other types of mechanisms, such as a Reduced Emissions from Deforestation and Forest Degradation (REDD +) mechanism, may also emerge.
9. For the purposes of this paper NMM will be considered to include a Sectoral Trading Mechanisms and a Sectoral Crediting Mechanism.
10. Other carbon market mechanisms will emerge regionally, nationally or sub-nationally, and will produce units according to their own standards, not subject to UNFCCC authority. We will label them **Domestic Market Mechanisms (DMM)** here. The units produced by DMM will be used for domestic compliance in the jurisdiction where they were produced. EU ETS (EUA), Japanese Bilateral Offset Crediting Mechanism (BOCM) and Australian ETS units, and others, are in this category.
11. There will be a linking of DMMs in different jurisdictions, with domestic units being provided with recognition and acceptance for compliance in the systems that are linked.
12. In some cases, there will be a desire for those that import domestic units originated from DMMs in other countries to use them, at the end of the UNFCCC compliance period, to comply with their obligations under the UNFCCC.
13. The COP will have the prerogative to provide recognition for the units that Parties can use to comply with UNFCCC obligations. There is a view that this assumption may be invalid. Should this be the case, the FVA may then play a different role.

3. Frameworks

It needs to be clearly stated what frameworks are under discussion, distinguish differences and state their scope. Two levels of framework can be identified: a) the framework of the climate change regime and b) the framework for linking different mitigation approaches, including market mechanisms, around the world.

The Kyoto Protocol was a two-in-one framework: a climate change regime/framework, which, because of its structure and components, also provided the tools to function as the framework for linking markets.

AAUs could ensure that international transfers of domestically issued units, could be shadowed by a UNFCCC issued unit, which ensured environmental integrity and avoided double counting. That is, when a EUA moved to another domestic ETS it could be 'shadowed' by an AAU, which kept the accounting system whole, and ensured environmental integrity.

Any units issued by countries that did not have a cap were issued under the CDM, by the CDM EB, an UNFCCC body, and were good for compliance. As such, all units that circulated internationally were UNFCCC recognised units, and good for compliance - CERs, Emissions Reduction Units (ERU) and AAUs.

Given some of the assumptions made above, we will need to distinguish between two frameworks under the new climate change architecture:

- The post-2020 (to be defined by 2015) **climate change regime/framework**, which defines:
 - o Obligations of Parties
 - o Ways of meeting them

- Other aspects, such as finance, technology, etc.
- **The FVA**, which will ensure that mitigation approaches around the world (market-driven and non-market), can be integrated into the climate change regime. The functions of the FVA are discussed below.

4. Framework for Various Approaches (FVA)

The FVA is a set of components and rules that will ensure that all approaches used for mitigation will be integrated, and receive recognition for UNFCCC compliance.

More specifically, through the FVA, units created by a DMM in a jurisdiction will qualify, under certain conditions, to be used for compliance with UNFCCC obligations, by a jurisdiction other than the one under which they were created.

The FVA is not concerned with activities that are purely of a domestic nature and do not result in international transfers of units in one way or another.

A fundamental principle should be that all activities that can be effectively regulated at a level other than the international one should be regulated at that level. Only those activities which, if not regulated internationally, would affect the integrity of the international climate change regime, should be regulated internationally.

The points made above are based on the assumption that only the COP has the prerogative to provide recognition for units used for UNFCCC compliance. If that is not the case, then the FVA takes on the role of safety net, providing, almost voluntarily, minimum standards for the characteristics of the units used.

5. Why is the FVA necessary?

The carbon market is by definition a regulatory market, and is being created to ensure that it minimises the overall cost to society of reaching environmental targets. As such, it is a price discovery mechanism that will help produce an economically rational asset allocation process. It exists to put a price on the ton of CO₂ that is reduced in different jurisdictions.

5.1 Environmental value

The very nature of the carbon market creates two values: an environmental value and a monetary value.

The **environmental value** represents the number of compliance tons of CO₂e (carbon dioxide equivalent) a unit issued in a jurisdiction is worth for compliance. This is something that the regulator decides upon, based on standards it can define, and potentially modify. This is not something that market participants can negotiate. It is a fixed value in terms of compliance, until the regulator decides otherwise.

Only the regulator can decide that a unit, issued under certain Monitoring Reporting and Verification (MRV) regime, and other conditions, equals one ton of CO₂e (or a percentage thereof) for compliance purposes. A regulator is free to accept or reject a unit for compliance, if that unit was not created according to specifications that it had defined, and over which it had no control.

Monetary value is one that is determined in the market place, and is what a market participant is willing to pay for that unit. It will fluctuate according to the:

- Liquidity of the unit in the marketplace
- Supply/demand balance
- Acceptance of the unit for compliance in different jurisdictions
- Environmental value of the unit

The FVA is needed because the Environmental Value is NOT a function of market forces, but a decision of the regulator that sets the rules for the climate regime and the carbon market that serve its purposes. The market cannot set environmental exchange rates for compliance purposes between units issued in different jurisdictions. Only a regulator that accepts different types of units for compliance can make that decision.

Rating agencies can rate the Monetary Value of different units. The Environmental Value in different jurisdictions will be one factor that will impact the Monetary Value of a unit.

5.2 Good market functioning

Good market functioning is highly dependent on having a liquid market, one that trades. With the notable exception of a few large countries, most economies are unlikely to have economies large enough to allow a liquid carbon market to function. Linking will not be a requirement for a jurisdiction that creates a carbon market. The linking of carbon markets will be seen as a necessity, and not a luxury.

Following the same logic, it is difficult to see how linking would take place in the absence of an FVA. It is unlikely that a Party would enter into linking agreements if it cannot have the assurance that units coming from a DMM in another jurisdiction can be used by that Party for UNFCCC/International compliance.

6. Objectives

The FVA that will have as objectives to ensure that:

1. Reductions from ALL mitigation approaches that create and transfer units internationally to be used for UNFCCC compliance obligations can be integrated into the UNFCCC system. This includes carbon markets (created nationally, regionally or sub-nationally) that create, but then transfer, the units outside the jurisdiction where they were created, for those units to be used for UNFCCC compliance. As mentioned above, that is equally true for reductions that are created through non-market approaches.
2. There is environmental integrity in the units that are being used for compliance with UNFCCC obligations. As there is no definition of environmental integrity, this will be an important element to define.
3. That accounting can be accomplished at the end of the compliance period. Accounting itself is not an objective or function of the FVA, providing the information is.
4. There is no double-counting. This is going to be a complex and fragmented scenario, with units issued by different authorities. The danger of double-counting is high and special care has to be taken to avoid endangering environmental integrity. It must also be noted that there are a number of types of double-counting.

7. Scope

The FVA, within the objectives outlined above, will have the following scope:

1. It will be under the authority of the COP. The FVA serves the objectives above, and can only function under the authority of the body that has created it, and whose objectives it serves.
2. It will include developed and developing countries. Some view the FVA as ensuring the export of offset units from developing to developed countries. It will have that function, but it should also cover linkages between developed countries.
3. It will have ability to integrate both crediting-type mechanisms, as well as trading ones.

4. It will cover only those approaches, mechanisms, and units that are used for UNFCCC compliance outside the jurisdiction where they were issued. The FVA will have no jurisdiction over activities that are of a domestic nature only, and do not affect the integrity of the international climate regime.

8. Components

The FVA will have a number of components:

- a) **International Compliance Unit (ICU)** – is a unit that will be good for compliance with UNFCCC obligations once issued. An ICU will have the following characteristics:
- A domestic DMM unit can become, as discussed below, an ICU, under certain conditions.
 - ICUs are issued by the International Transaction Log (ITL), on demand, once the DM that creates them meets the necessary criteria.
 - ICUs are good for international compliance.
 - Once issued, they can be transferred freely between national registries.
 - ICUs will allow the identification of the origin of the unit (country, project, vintage, etc.).
 - An ICU will be recognised in any commercial transaction as being accepted for compliance with UNFCCC obligations and contribute to a more liquid market.
- b) **Standards for Environmental Integrity (SEI)**. This will be a set of standards that preserve the environmental integrity of the international system. It will be defined by the MRB, and approved by the COP. The SEI will be used in ‘evaluating’ a DMM, through different processes, before it can request that ICUs be issued in exchange for the domestic units it had issued. They will include:
- Additionality, where appropriate
 - Baseline methodologies and crediting threshold
 - An MRV approach
 - Third party verification
- It should be emphasised that while the SEI will be defined at the international level, implementation (e.g. baselines) will be done at the national level etc. As such, some interaction can be envisaged between the national and international levels, for the SEIs to address local realities.
- c) **International Transaction Log (ITL)** – will have a number of functions and characteristics
- Will be operated by the UNFCCC
 - Will be able to issue ICUs upon verification that they are issued for a unit originated from an DMM that has followed the appropriate steps
 - Can accept filtering instructions with respect to the origin of ICUs. These instructions will be publicly available and will contribute to the development of a liquid market.
 - Will transfer ICUs between National Registries.
- d) **Market Regulatory Board (MRB)**. This regulator, which should be merged with the CDM Executive Board (CDM EB) to ensure that all international market regulation is carried out in a coherent way, will have the following functions and characteristics:
- Established under the COP
 - Will manage all mechanisms internationally – CDM, NMM, etc. and the international part of DMM that are created nationally, etc.
 - Will develop, implement and monitor International Standards, as discussed above.

It should be underlined that the CDM EB is an international regulator that already exists. Other bodies with regulatory powers also exist within the UNFCCC. As such, this is not a new development, and does not call for the creation of new bodies under the UNFCCC, but simply the transformation, and possible amalgamation, of existing ones.

e) National Registries (NR)

- a. An NR will be operated by authorities at national level.
- b. NRs will be linked to the ITL, and will issue domestic units, for domestic compliance.
- c. Once a DMM has gone through the process of the Market Regulatory Board, a National Registry will be able to request the ITL to issue an ICU for any unit domestic unit that needs to be transferred internationally.

9. Functions of the FVA

The FVA will accomplish its objectives by fulfilling the following functions:

1. Review DMMs and implement SEI. The FVA will have two tracks:

- Track 1 (T1 - Review & Approval Track) and
- Track 2 (T2 - Review & Transparency Track).

Review and Approval Track. Under T1, the regulatory body operating the FVA, under the authority of the COP, will review, and approve, a DMM that has applied for recognition. This will entitle any units issued by it to become ICUs.

Review and Transparency Track. Under T2, the regulatory body will provide the facilitation for the DMM to be peer reviewed, using the Standards for Environmental Integrity as guidelines. Once the review is complete the results will be published. There is no approval process under T2. Once a DMM goes through T2 it also becomes an 'international' DMM, and its units can become ICUs.

Different alternatives can be envisaged, depending on the assumptions made. For example, *T2 can be the default track, with T1 only used on demand.*

T1/T2 can be envisaged as a public process, including a hearing-type approach. It can, and should be, envisaged that a DMM has to go through an initial process, but that review process should take place periodically. In addition, its functioning could be tested using an audit-type process.

2. Transfer units internationally. The FVA will ensure that, upon request, units are transferred between national registries.

3. Tracking units internationally. The FVA will ensure that ICUs are tracked internationally, and that it has all the information to locate any particular unit at any given time.

4. Issuance of ICUs. Through the ITL, the FVA will issue ICUs for any DMM unit, upon demand, and upon the DMM going through T1 or T2.

5. Avoid double-counting. Double-counting will be checked, by the national registry (NR), at the national level, upon issuance of domestic units. A national registry will have all necessary data to identify projects and installations that are part of any DMM.

A national registry will also have data on any UN mechanism, such as CDM, as they need to issue a Letter of Approval. To have double-counting checked internationally would imply that the regulatory body, and/or the ITL, would have to track all DMMs, in every country. This is not efficient, and not in keeping with the fundamental principle of doing things at the national level wherever possible.

10. Net avoidance of emissions

The Durban decisions, and all recent discussions, have made it clear that an offsetting approach is not one that can be contemplated. Under the new climate change regime what is needed are net emission reductions.

Based on the points raised above, we see and expect the emergence of a variety of approaches around the world. Net emissions reduction can be achieved in a variety of ways but ensuring consistency at the source of production of these reductions may require a great deal of effort and coordination – such as ensuring that the same definition of conservatism is applied in very different circumstances and jurisdictions.

A different approach may be one where a discount factor is applied consistently at the point of use, which will have the effect of keeping clear measurement to ‘a ton is a ton’, and not making arbitrary and differing conservative assumptions. At the same time, applying a discount factor at the point of use ensures a simple and clear net reduction.

11. Financing of the FVA

The CDM was financed by a Share of Proceeds from the issuance of CERs. In this case the situation is more complex as the FVA will only cover internationally transferred units, many issued at first domestically.

In this case the potential option is a levy on any ICUs issued. This will capture any units that are issued domestically, but then use the FVA for international transfer and compliance purposes.

12. Functioning

Based on the assumptions made in point 2 above, there are two distinct scenarios that emerge: one for countries that have economy or sector-wide caps, and one for those that do not have such caps.

Countries/sectors of the economy with caps

In this case, any DMM unit that is issued domestically, and which is then transferred as an ICU, will be added to the inventory of the issuing country, and will be accounted for at the end of the compliance period.

This system can be deemed as *ex post*. However, modalities to ensure its functioning will need to be worked out as part of the climate change regime, not the FVA.

As such, it can be said that Parties that have economy-wide caps and transfer units internationally ‘guarantee the environmental integrity’ of that unit. Any country/sector with a cap can request the issuance of ICUs for their DMM.

For illustration purposes, the EU can request the issuance of an ICU for a EUA, without having the EU ETS having to go through T1 or T2. The EUA is ‘guaranteed’ by the EU inventory at the end of the compliance period.

Figure 3 illustrates the mechanics of the issuance of an ICU and its transformation and transfer, from a domestic unit from a Party with a cap.

When a domestic unit is issued, the NR checks for double-counting, as it will have all in its databases, and all activities under DMM, and CDM, etc. Once the domestic unit is issued, the owner can request the NR to issue an ICU.

That request is transmitted to the ITL, which verifies that it is issued from a DMM in a Party with a cap. The ITL then issues the ICU, and checks any filtering instructions from the receiving Party, prior to making the transfer.

Figure 3. Unit flow – Parties with caps

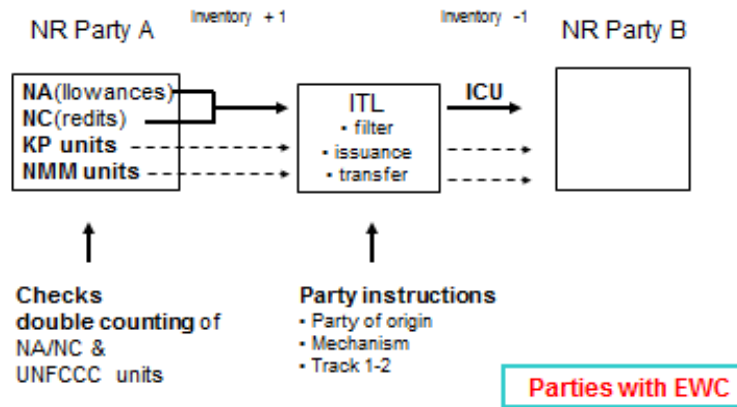

If the request for transfer is for an ICU, or a unit from a UN-issued unit (e.g. CER), that transfer is done automatically, after filtering instructions from the receiving Party are checked.

From a transactional point of view this is totally transparent as the owner of the sending account is notified that the transfer has taken place for X number of units, and its account debited accordingly. For the receiving account, the owner is notified that it has receiving X number of ICUs with the respective identifiers.

Countries without caps

In the case of countries without a cap, there is no end of compliance period obligation. As such, there is no guarantee by the issuing country of the environmental integrity of the unit that is first issued domestically, and for which it then requests the issuance, and international transfer, of an ICU.

As such, any DMM that requests units to be transferred internationally, to be used for UNFCCC compliance, will need to go through a T1 or T2 process. Figure 4 illustrates the flow of the process in this case.

Figure 4. Unit Flow – Parties without caps

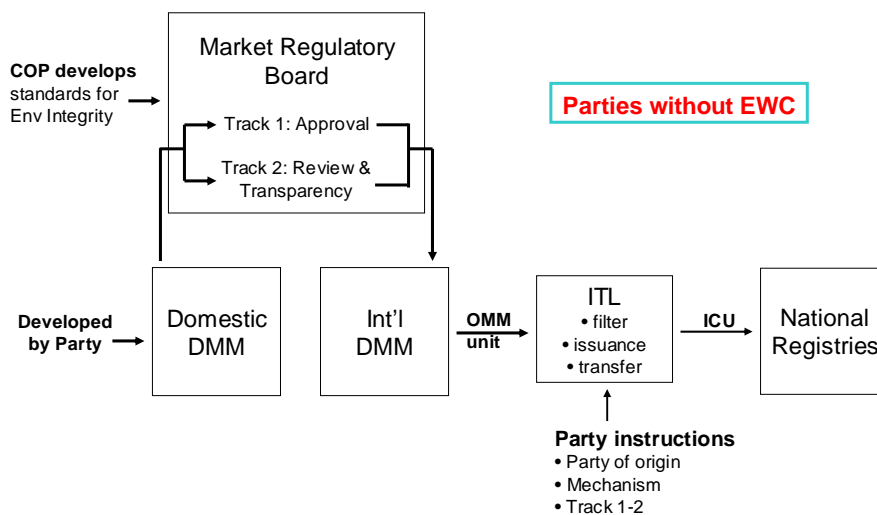

If the DMM is submitted for UNFCCC recognition by a Party without a cap, that Party has a choice of tracks. If it chooses to go through T1, then the MRB will review it, and have the authority to approve or reject it. The DMM will be tested against the already defined, and COP approved, Standards for Environmental Integrity. It must be again noted that it will be the DMM, and not individual units that are the object of the review. Once approved, any domestic unit issued by that DMM may be transformed, upon request, for international transfer into an ICU.

If the Party chooses T2, then the DMM will be submitted to a peer review process that will be facilitated by the MRB. Once the process is complete, the results of the review are published. At that point any owner of a unit issued by that DMM may ask for an international transfer to another NR. The ITL will issue an ICU and that ICU will not be treated any differently from any other ICU.

13. Conclusions

The FVA is thus not a luxury, but a necessity. While not well understood and currently undefined, it is likely to emerge as one of the key components of the new climate change regime.

This tells us that we do not have the luxury of time. National systems are evolving rapidly and they are starting to link; it is no longer simply an academic exercise.

So what is needed from the Doha COP in order to move forward? At the very least, we need 'political' direction on some fundamental elements that constitute the FVA: objectives, scope, and components, including some direction on the functions of each component.

A negotiated text that leaves too many of these fundamental building blocks unaddressed, or open to interpretation, will only lead to the creation of an FVA that, like the Clean Development Mechanism (CDM), will require years of work and retrofit before it can realise its potential.



ABOUT CEPS

Founded in Brussels in 1983, the Centre for European Policy Studies (CEPS) is widely recognised as the most experienced and authoritative think tank operating in the European Union today. CEPS acts as a leading forum for debate on EU affairs, distinguished by its strong in-house research capacity, complemented by an extensive network of partner institutes throughout the world.

Goals

- Carry out state-of-the-art policy research leading to innovative solutions to the challenges facing Europe today,
- Maintain the highest standards of academic excellence and unqualified independence
- Act as a forum for discussion among all stakeholders in the European policy process, and
- Provide a regular flow of authoritative publications offering policy analysis and recommendations,

Assets

- Multidisciplinary, multinational & multicultural research team of knowledgeable analysts,
- Participation in several research networks, comprising other highly reputable research institutes from throughout Europe, to complement and consolidate CEPS' research expertise and to extend its outreach,
- An extensive membership base of some 132 Corporate Members and 118 Institutional Members, which provide expertise and practical experience and act as a sounding board for the feasibility of CEPS policy proposals.

Programme Structure

In-house Research Programmes

Economic and Social Welfare Policies
Financial Institutions and Markets
Energy and Climate Change
EU Foreign, Security and Neighbourhood Policy
Justice and Home Affairs
Politics and Institutions
Regulatory Affairs
Agricultural and Rural Policy

Independent Research Institutes managed by CEPS

European Capital Markets Institute (ECMI)
European Credit Research Institute (ECRI)

Research Networks organised by CEPS

European Climate Platform (ECP)
European Network for Better Regulation (ENBR)
European Network of Economic Policy
Research Institutes (ENEPRI)
European Policy Institutes Network (EPIN)